



KNIFE GATE VALVES

A LUG SERIES

HANDWHEEL with Non-Rising Stem

- Suitable when no size limitations exist.
- **B = max. width** of the valve (without actuator).
D = max. height of the valve (no actuator).
- Options:
 - Square nut.
 - Limiting switches.
 - Extensions: stand, pipe, plates,...
 - DN higher than those shown in the table.
- Actuator including:
 - Handwheel.
 - Stem.
 - Guide bushing on the yoke.
 - Nut.
- Available: DN50 to DN1200, other DN on request.
- From DN600 the actuator is with gears.

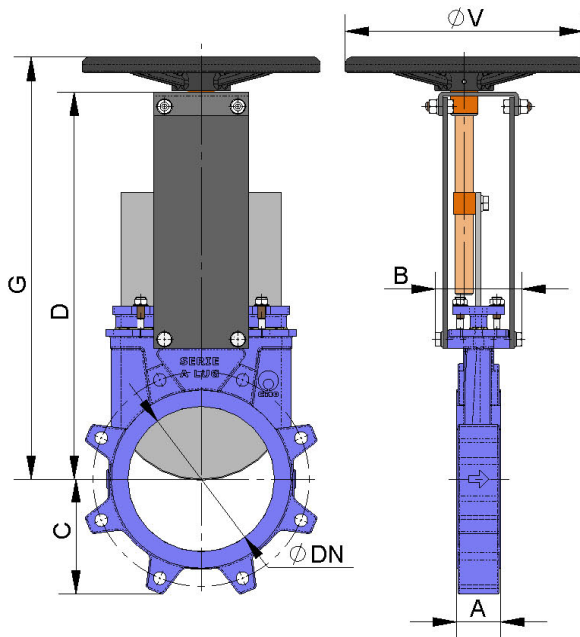

fig. 18

DN	ΔP (Kg/cm ²)	DRAW (Nw)	TORQUE (Nm)	A	B	C	D	G	ϕV
50	10	830	1,91	40	91	61	241	280	225
65	10	1400	3,22	40	91	68	268	308	225
80	10	2120	4,9	50	91	91	294	333	225
100	10	3310	7,61	50	91	104	334	373	225
125	10	5180	11,9	50	101	118	367	407	225
150	10	5970	14	60	101	130	419	458	225
200	8	9300	27	60	118	159	525	578	325
250	6	10400	30	70	118	196	626	679	325
300	6	15000	43	70	118	231	726	779	380
350	5	16380	63	96	290	257	797	906	450
400	5	21430	83	100	290	290	903	1012	450
450	3	20044	79	106	290	312	989	1098	450
500	3	25230	98	110	290	340	1101	1210	450
600	3	36510	142	110	290	398	1307	1416	450
700	2	32945	180	110	320	453	1506	--	--
800	2	43493	238	110	320	503	1720	--	--
900	2	55024	301	110	320	583	1953	--	--
1000	2	68580	375	110	320	613	2137	--	--
1200	2	99026	643	150	340	728	2616	--	--

table 5